

ITEM NO.	QTY.	PART NO.	DESCRIPTION	ITEM NO.	QTY.	PART NO.	DESCRIPTION
1	1	P731 (1003HV)	BASE, SPEEDSTER	59	4	H770	BOLT, 1/4-20 x 1/2" LG. SERRATED FLANGE
2	3	H296	COOLING FAN WIRE GUARD	60	2	H204	BOLT, 1/4-20 x 1-3/4" LG. HEX HEAD
3	12	H297	SCREW, SLEF-TAPPING, #8 x 1/2" LG.	61	1	H896	LATCH BRACKET
4	1	C317	FAN, COOLING (115V)	62	2	H922	THUMB SCREW, BLACK PLASTIC
5	1	H253	PLATE, DUAL MANIFOLD, 9" x 13"	63	2	H602	"L" BRACKET
6	16	H210	WASHER, FLAT, 1/4"	64	8	H877	#10 LOCK WASHER
7	10	H342	BOLT, HEX HD., 1/4-20 x 1" LG.	65	8	H230	SCREW, #10-32 x 1/2" LG. PHIL. PAN HD.
8	12	H216	LOCKNUT, 1/4-20 HEX, NYLON INSERT	66	1	B107	NIPPLE, 1/4" HEX
9	2	P735	SINGLE MANIFOLD	67	1	AH105	HOSE, 3/8" SURGE x 15-3/4" LG.
10	2	G004	GASKET, VACUUM MOTOR	68	2	H413	WASHER, NYLON
11	2	C302	MOTOR, 3 STAGE 115V	69	2	B106	NIPPLE, 1/4" CLOSE
12	4	H217	HOSE CLAMP	70	1	B102	QUICK DISCONNECT, 1/4" FEMALE
13	1	G059	EXHAUST BOOT, PLASTISOL	71	1	B186	ELBOW, 90 DEG, 3/8" M x FM
14	6	H768	BOLT, 1/4-20 x 3/4" LG. SERRATED FLANGE	72	2	H299	WASHER, .688 x 1.50 x .075
15	6	H501	3-STAGE VACUUM SUPPORT	73	1	B216	NIPPLE, 3/8" CLOSE
16	6	H201	BOLT, 1/4-20 x 1/2" LG. HEX HEAD	74	1	B210	BUSHING, 1/2 m x 3/8 fm
17	1	PH627 (Speedster1)	VACUUM HOSE, 1-1/2" x 22" LG.	75	1	B119A	FILTER STRAINER, 1/2"
18	2	H300	HOSE CUFF, 1-1/2"	76	2	H203	HEX BOLT, 1/4-20 x 1-1/4" LG.
19	1	G059 (MODIFIED)	EXHAUST BOOT, PLASTISOL	77	2	H213	1/4" LOCK WASHER
20	1	PH627 (Speedster2)	VACUUM HOSE, 1-1/2" x 22" LG.	78	4	H211	WASHER, 1/4" ID x 1" OD
21	1	C313	PUMP, 450 psi	79	4	G052	BUNA WASHER, 1-1/8" OD x 3/16" ID
22	6	B103	90 DEG 1/4" M x FM	80	2	H215	1/4-20 HEX NUT
23	1	H902	PRIME VALVE SETUP	81	1	P733 (1003HV)	VACUUM TANK, SPEEDSTER
24	2	B116	FERREL (FOR 1/4" HOSE)	82	1	PH634-03	HOSE, 1/4" KURITEK x 3" LG.
25	1	PH634-25	HOSE, 1/4" KURITEK x 25" LG.	83	1	B109	FITTING, 1/4" BARB x 1/4" MPT
26	2	B110	FITTING, 1/4 BARB x 1/4 FM SWIVEL	84	1	B119	FILTER STRAINER, 1/4"
27	6	H347	HOSE CLAMP	85	1	H225	DRAIN VALVE, 1-1/2"
28	1	PH615-12	HOSE, 1/2" KURITEK x 12" LG.	86	1	H226	DRAIN SPOUT, 45 DEG.
29	1	B175	IN-LINE FILTER	87	3	H229	INLET FITTING, PVC, GRAY, 1-1/2"
30	1	PH615-14	HOSE, 1/2" KURITEK x 14" LG.	88	2	H244	ADAPTER, PVC, 1-1/2"
31	2	B160	FITTING, 1/2 BARB x 3/8 FM SWIVEL	89	2	PH633-11	PIPE, PVC, 1-1/2" x 11" LG.
32	1	PH615-22	HOSE, 1/2" KURITEK x 22" LG.	90	2	P755	ELBOW FOR FLOAT ASSEMBLY
33	1	B136	90 DEG 1/4" M x M	91	2	H235	FLOAT CAGE
34	12	H289	WASHER, FLAT, #10	92	1	G060	VACUUM LID GASKET
35	2	H273	KEP-NUT, #10-32, ZINC	93	1	G056	LID, VACUUM TANK
36	2	H222	#10-32 x 1-1/4" LG. PHIL. PAN HD. SCREW	94	6	H304	SCREW, #8-32 x 5/8" LG. PHIL. OVAL
37	1	H439	HEATER ASSEMBLY, DUAL CAPSULE	95	1	G010	BAG, FILTER
38	2	E519	HEATING ROD, 1000W, 115V	96	1	A925	INLET ELBOW ASSEMBLY
39	2	E573	THERMOSTAT, 210 DEG AUTO	97	1	G001	GASKET, INLET, 1-1/2"
40	8	H447	NUT, KEP, M3	98	1	H337	SWITCH PLATE, 4-HOLE
41	2	E574	THERMOSTAT, 375 DEG MANUAL	99	2	H612	#8 FLAT WASHER
42	2	AH108S	HOSE, 1/4" x 22" LG. (W/ FITTINGS)	100	2	H246	SCREW, #8-32 x 3/8" LG. SOCKET HD. CAP
43	1	H371	AXLE, 1/2" x 18-1/2" LG.	101	1	E512	LIGHT, GREEN CIRCUIT INDICATOR
44	2	H251	WHEEL, 12"	102	3	E515	SWITCH, 2 POSITION ROCKER
45	4	H254	WASHER, AXLE, 5/8" ID	103	1	E516	3 POSITION ROCKER SWITCH
46	2	H219	1/2" AXLE CAP	104	1	H308C	GAUGE, PRESSURE
47	2	H666	CASTER, 5" DIA.	105	2	H375	HANGER, WIRE FORMED
48	2	H220	CORD STRAIN RELIEF FITTING				
49	2	H221	1/2" STEEL LOCK NUT				
50	2	E550	30" POWER CORD PIGTAIL				
51	2	G131	CONNECTOR, CORD				
52	2	E530	POWER CORD, 50'				
53	1	P732 (1003HV)	SOLUTION TANK, SPEEDSTER				
54	1	B105	REDUCER, 3/8" M x 1/4" FM				
55	8	H876	1/2" FLAT WASHER				
56	3	B111	ADAPTER, 1/4" M x 1/4" FM				
57	1	G018A	COVER, SOLUTION TANK (FB & SPEEDSTER)				
58	1	H378	BRACKET, FRONT HINGE				

ADDITIONAL COMPONENTS NOT SHOWN:

WIRING HARNESS COMPONENTS

- E513 - WIRE TIES, SMALL
- L401A - BOX, MACHINE
- L401B - BOX, TOP TRAY
- L478 - BOX, BOTTOM SUPPORT
- L809 - LABEL SET, SPEEDSTER 1003
- L829 - LABEL SET, SAFETY
- L854 - LABEL, HIGH VELOCITY

PROPRIETARY AND CONFIDENTIAL
 THE INFORMATION CONTAINED IN THIS DRAWING IS THE SOLE PROPERTY OF MYTEE PRODUCTS, INC. ANY REPRODUCTION IN PART OR AS A WHOLE WITHOUT THE WRITTEN PERMISSION OF MYTEE PRODUCTS, INC. IS PROHIBITED.

REVISIONS				
ZONE	REV.	DESCRIPTION	DATE	APPROVED
	A	DIFF. HOSE/BRASS FITTINGS IN VAC TANK	12/11/03	
	B	REPLACED H212 WITH H876	4/22/04	
	C	NEW HEATER; ADDED WIRE HANGERS	8/27/04	

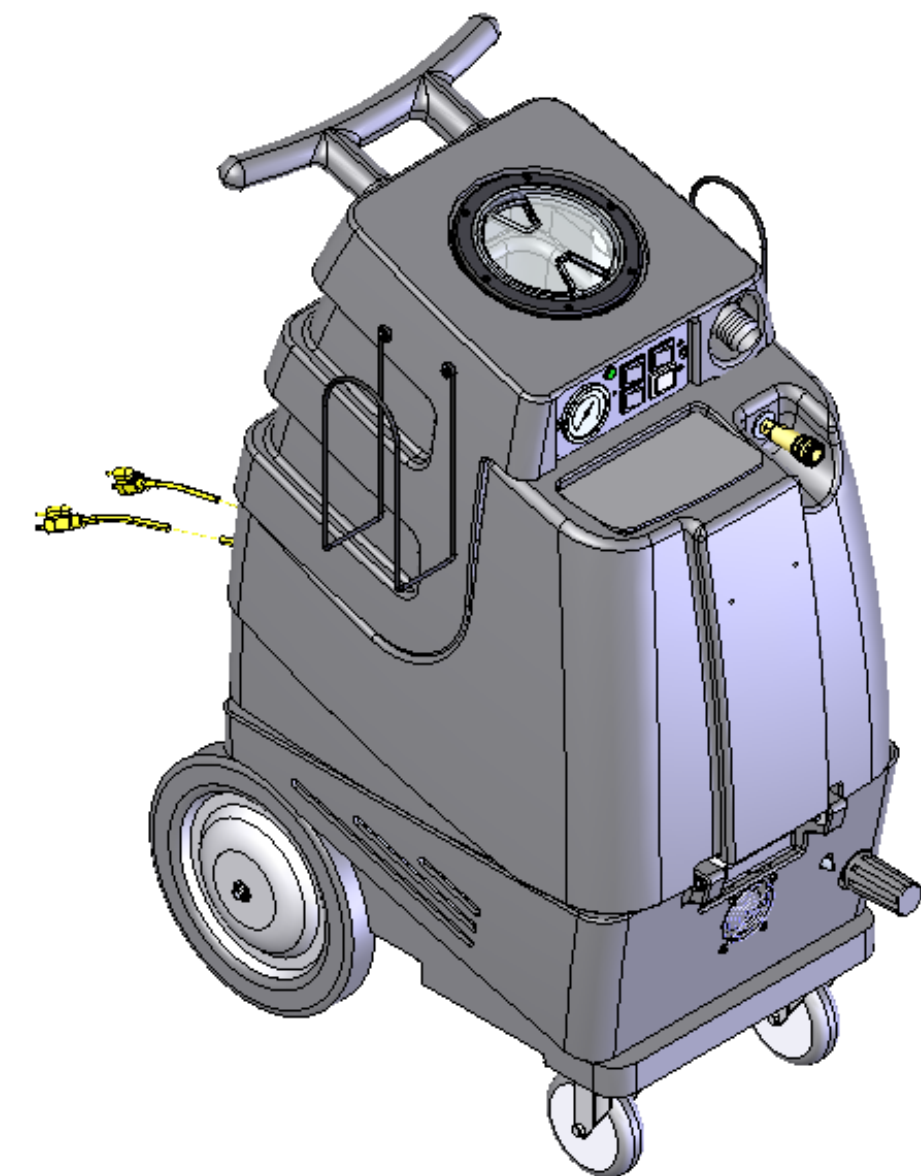

UNLESS OTHERWISE SPECIFIED:		DATE	NAME	MYTEE PRODUCTS, INC.	
DIMENSIONS ARE IN INCHES		DRAWN	11/28/03		J. BEVIER
TOLERANCES:		CHECKED			
FRACTIONAL: ± .015		ENG APPR.			
ANGULAR: MACH ±		MFG APPR.			
TWO PLACE DECIMAL ± .010		COMMENTS:			
THREE PLACE DECIMAL ± .005					
MATERIAL		SEE B.O.M.			
FINISH					
NEXT ASSY	USED ON				
APPLICATION		USED ON:			

TITLE:
SPEEDSTER, 1003HV ASSEMBLY

SIZE **C** DWG. NO. **00004** REV **C**

SCALE: 1:8 DO NOT SCALE DRAWING SHEET 1 OF 4

REVISIONS				
ZONE	REV.	DESCRIPTION	DATE	APPROVED
A		DIFF. HOSE/BRASS FITTINGS IN VAC TANK	12/11/03	
B		REPLACED H212 WITH H876	4/22/04	
C		NEW HEATER; ADDED WIRE HANGERS	8/27/04	

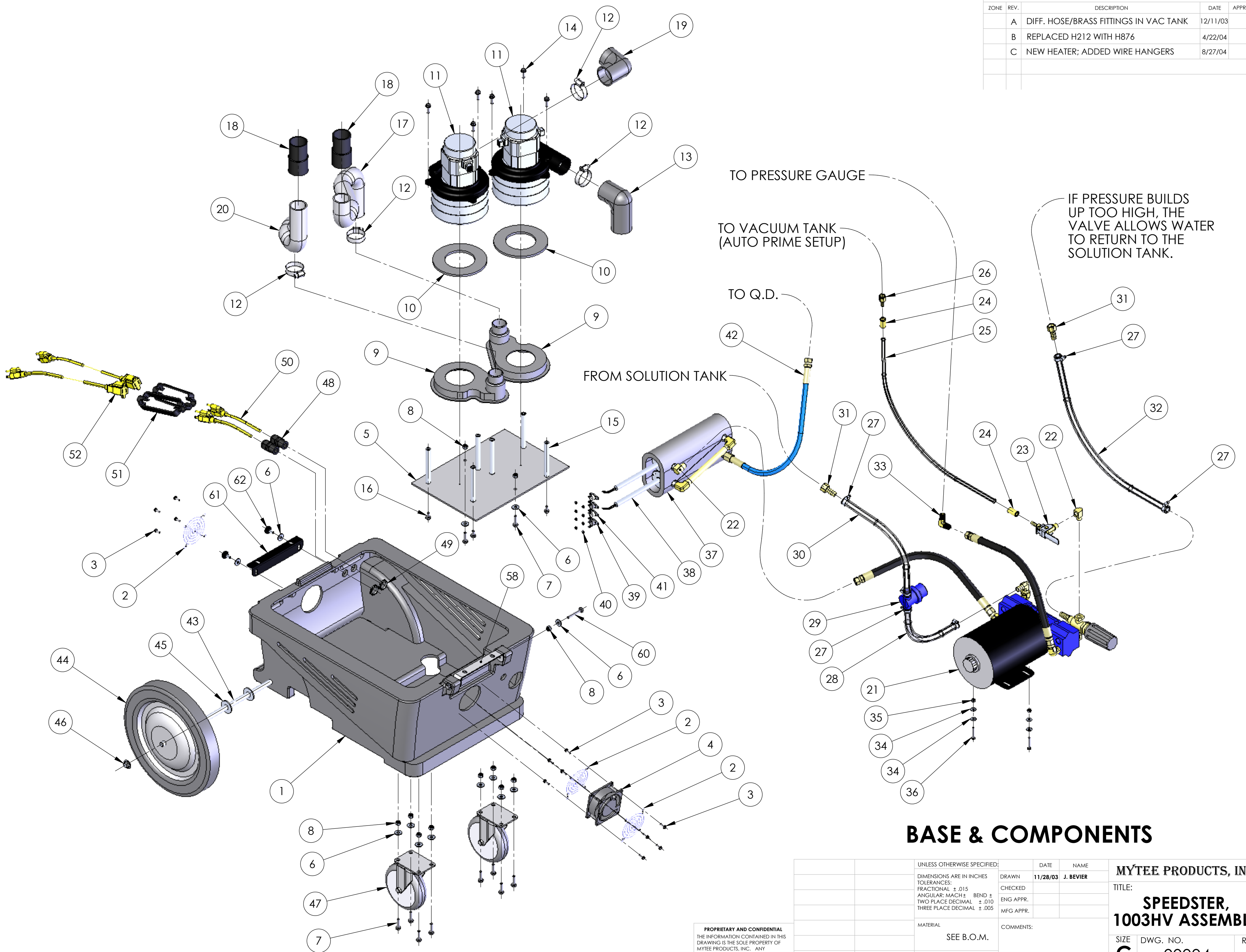

BASE & COMPONENTS

PROPRIETARY AND CONFIDENTIAL
 THE INFORMATION CONTAINED IN THIS DRAWING IS THE SOLE PROPERTY OF MYTEE PRODUCTS, INC. ANY REPRODUCTION IN PART OR AS A WHOLE WITHOUT THE WRITTEN PERMISSION OF MYTEE PRODUCTS, INC. IS PROHIBITED.

UNLESS OTHERWISE SPECIFIED:		DATE	NAME	MYTEE PRODUCTS, INC. TITLE: SPEEDSTER, 1003HV ASSEMBLY SIZE DWG. NO. REV C 00004 C SCALE: 1:6 DO NOT SCALE DRAWING SHEET 2 OF 4
DIMENSIONS ARE IN INCHES		DRAWN	11/28/03 J. BEVIER	
TOLERANCES: FRACTIONAL: ± .015 ANGULAR: MACH ± BEND ± TWO PLACE DECIMAL ± .010 THREE PLACE DECIMAL ± .005		CHECKED		
MATERIAL SEE B.O.M.		ENG APPR.		
FINISH		MFG APPR.		
NEXT ASSY	USED ON	COMMENTS:		
APPLICATION		USED ON:		

REVISIONS				
ZONE	REV.	DESCRIPTION	DATE	APPROVED
	A	DIFF. HOSE/BRASS FITTINGS IN VAC TANK	12/11/03	
	B	REPLACED H212 WITH H876	4/22/04	
	C	NEW HEATER; ADDED WIRE HANGERS	8/27/04	

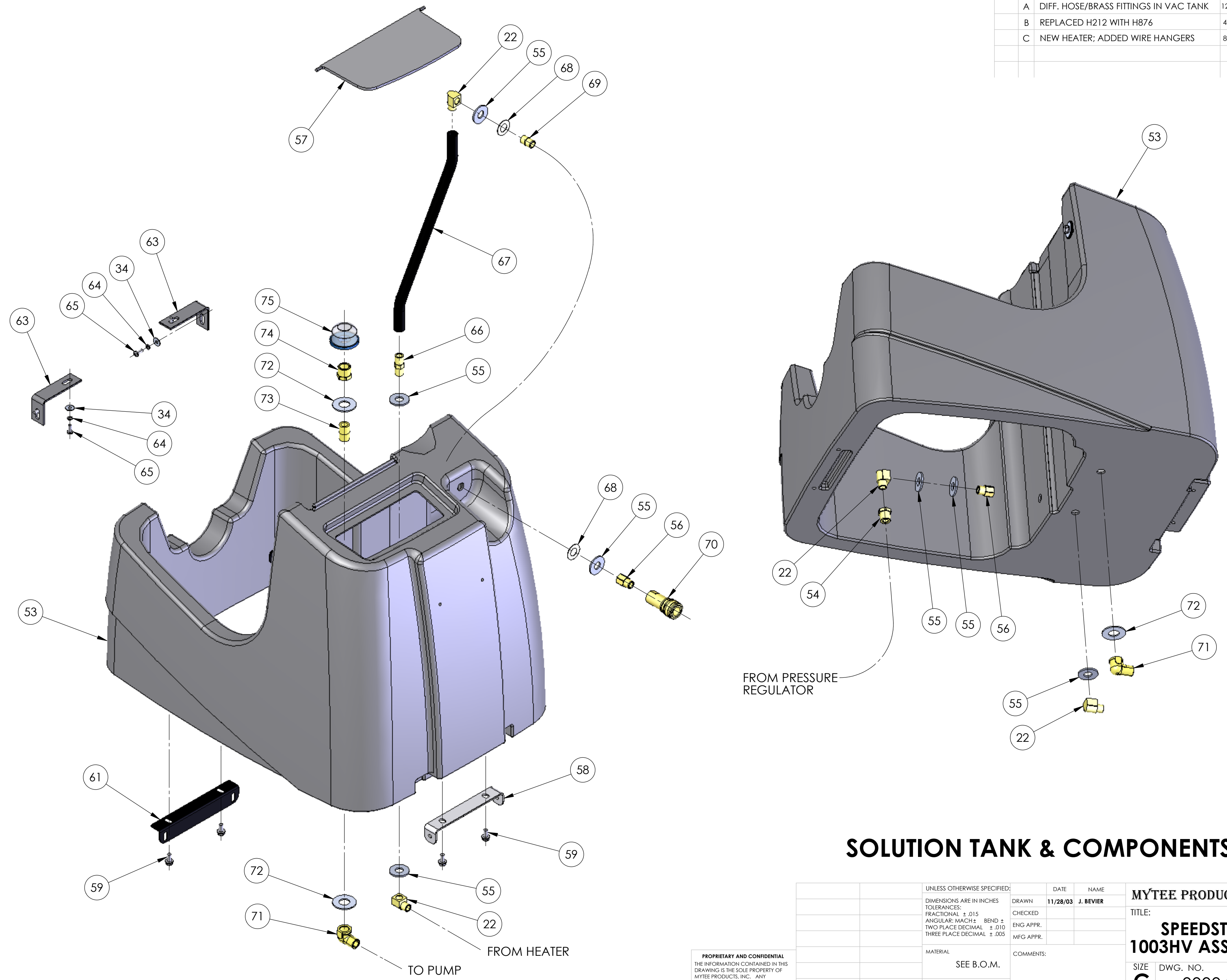

SOLUTION TANK & COMPONENTS

PROPRIETARY AND CONFIDENTIAL
 THE INFORMATION CONTAINED IN THIS DRAWING IS THE SOLE PROPERTY OF MYTEE PRODUCTS, INC. ANY REPRODUCTION IN PART OR AS A WHOLE WITHOUT THE WRITTEN PERMISSION OF MYTEE PRODUCTS, INC. IS PROHIBITED.

UNLESS OTHERWISE SPECIFIED:		DATE	NAME	MYTEE PRODUCTS, INC.
DIMENSIONS ARE IN INCHES TOLERANCES: FRACTIONAL: ± .015 ANGULAR: MACH ± BEND ± TWO PLACE DECIMAL ± .010 THREE PLACE DECIMAL ± .005		11/28/03	J. BEVIER	
MATERIAL		COMMENTS:		TITLE:
SEE B.O.M.				SPEEDSTER, 1003HV ASSEMBLY
NEXT ASSY	USED ON	FINISH	USED ON:	SIZE DWG. NO. REV
				C 00004 C
APPLICATION			SCALE: 1:4	DO NOT SCALE DRAWING SHEET 3 OF 4

REVISIONS				
ZONE	REV.	DESCRIPTION	DATE	APPROVED
A		DIFF. HOSE/BRASS FITTINGS IN VAC TANK	12/11/03	
B		REPLACED H212 WITH H876	4/22/04	
C		NEW HEATER; ADDED WIRE HANGERS	8/27/04	

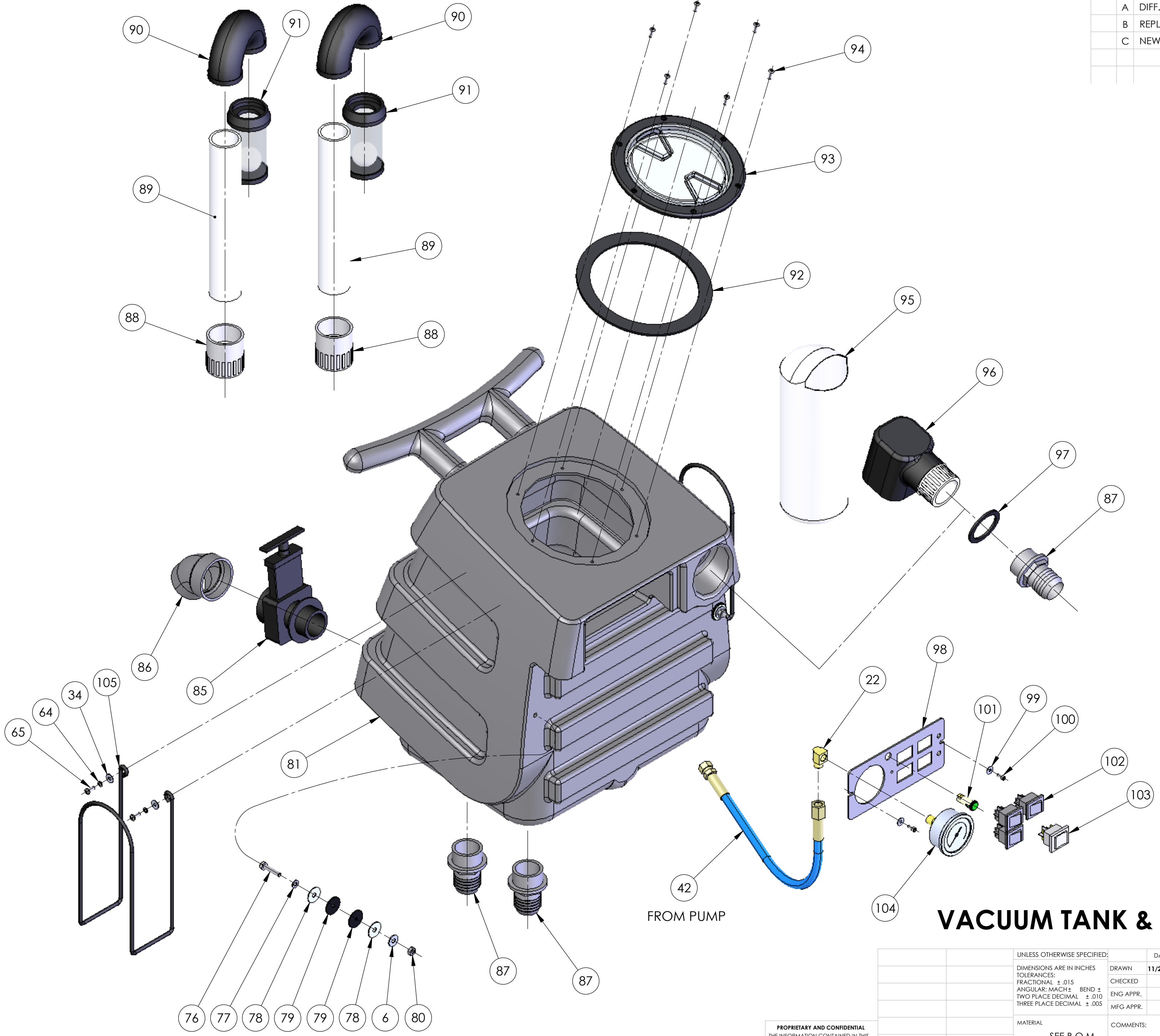

THESE FASTENERS HOLD THE SOLUTION TANK AND VACUUM TANK TOGETHER.

FROM PUMP

VACUUM TANK & COMPONENTS

PROPRIETARY AND CONFIDENTIAL
 THE INFORMATION CONTAINED IN THIS DRAWING IS THE SOLE PROPERTY OF MYTEE PRODUCTS, INC. ANY REPRODUCTION IN PART OR AS A WHOLE WITHOUT THE WRITTEN PERMISSION OF MYTEE PRODUCTS, INC. IS PROHIBITED.

UNLESS OTHERWISE SPECIFIED:		DATE	NAME	MYTEE PRODUCTS, INC. TITLE: SPEEDSTER, 1003HV ASSEMBLY SIZE C DWG. NO. 00004 REV C SCALE: 1:4 DO NOT SCALE DRAWING SHEET 4 OF 4
DIMENSIONS ARE IN INCHES		DRAWN	11/28/03 J. BEVIER	
TOLERANCES:		CHECKED		
FRACTIONAL: ± .015		ENG APPR.		
ANGULAR: MACH ±		MFG APPR.		
TWO PLACE DECIMAL ± .010		COMMENTS:		
THREE PLACE DECIMAL ± .005				
MATERIAL		SEE B.O.M.		
FINISH				
NEXT ASSY	USED ON	APPLICATION		